

MULTI-CLASS CLASSIFICATION OF SKI DISEASE

B Kishore, Dr M Varaprasad Rao, Deepa Vujjini
Assistance professor, Associate professor, Assistance professor

Department Of CSE
Sree dattha institute of engineering and science

ABSTRACT

The functionality of skin plays a vital role in the human body since it is the largest organ which covers the muscles, bones, and other parts of the body. Once the functionality of skin goes wrong it affects the other parts of the body. Skin is the most sensitive part, therefore when it is exposed to sunlight and other environmental pollution tends to occur skin cancer. Skin cancer appears to be of two kinds Benign and Melanoma form. Benign is just the moles on the skin which do not penetrate inside, whereas Melanoma causes sores on the skin which leads to bleeding, and it is named after cells Melanocytes which is more hazardous. In United States, more than 700,000 skin lesions are diagnosed annually under the estimation of American Cancer Society. According to statistics given by Apollo and other hospitals, it suggests that Melanoma affects the ages ranging from 41-60+. There are technologies that are used to detect skin cancer at the early stages. Skin Cancer detected in advance can save people's lives and it eliminates the multiplication of cancer cells across the parts of the body. Although it affects people within age limits but high probably is for bright skin people. It will be hard for even an experienced dermatologist to detect skin cancer or to predict the stages. Therefore, much hardware & software devices and applications evolved. In addition, cancer of the skin is the most common form of the disease and is responsible for millions of deaths each year. The early detection of potentially hazardous skin cancer cases and the administration of suitable treatments are essential components in ensuring a low mortality rate while maintaining a high survival rate. Most of the relevant studies concentrate on algorithms that are based on machine learning. However, these algorithms are unable to deliver the highest possible level of accuracy and specificity. During the preprocessing step, enhancing procedures including sharpening filters and smoothing filters are employed to reduce noise from the image. So, deep learning convolution neural network (DL-CNN) was designed for the multi-class classification of skin cancer in order to archive the system's maximum efficiency and contribute to this study. Therefore, the findings of the study may be successfully applied to the categorization of all nine distinct forms of skin cancer.

Keywords: Skin cancer, Multi class classification, CNN.

1. INTRODUCTION

Since the 1970s, skin cancer has held the title of the most prevalent disease globally. Over the previous several decades, there has been an uptick in people diagnosed with nonmelanoma and melanoma skin cancers, respectively. Melanoma can be identified in that only one in three cases of cancer, as stated by the World Health Organization (WHO), and according to statistics provided by the Skin Cancer Foundation, one out of every five people in the United States will develop skin cancer at some point during their lifetime. For the past several centuries, the incidence of skin cancer has risen at a relatively constant rate, particularly in the Western hemisphere. Countries such as the United States, Canada, and

Australia are just some of the places where this trend has been observed. Infectious diseases of the skin typically have the potential to have a significant detrimental effect on the overall health of people all over the world. According to one piece of a study released in 2017, multiple studies have demonstrated that skin cancer is responsible for 1.79 percent of the disease burden assessed in disability-adjusted life years on a global scale [1]. The incidence of skin cancer accounts for around 7 percent of all newly diagnosed instances of cancer worldwide [2], resulting in a loss of more than \$8 billion for the Medicare program in the United States in 2011. Clinical data suggest that there are such disparities in results based on race in the case of skin cancer: Even though people with darker skin tones are approximately 20 to 30 times as likely to develop melanoma than those who have lighter skin tones, it has been discovered that people with darker skin tones either have a higher or lower mortality risk for specific types of melanomas, depending on their skin tone.

To administer the appropriate treatment, it is essential to identify a skin lesion correctly. It is possible to accomplish early diagnosis of melanoma in dermoscopy photographs and pictures using this method, which improves the survival rate.

Dermatologists who have had considerable training in the many skin lesions that melanomas might cause are the most qualified to make an accurate diagnosis. Because of this, diagnosing melanoma can be a challenging task because there is no clear separation between skin lesions and the skin itself, malignant and non-melanoma skin lesions appear visually similar, and there are other factors to consider. Therefore, creating a trustworthy automatic detection method for skin tumors, such as a system that can automatically analyze skin lesions, will be greatly useful to pathologists. This is especially relevant in an era where knowledge is scarce.

According to the findings of this study, the classification methods of K-nearest Neighbors, Support Vector Machines, and Decision Trees all produced subpar results in terms of precision and accuracy. After conducting further research into the mathematics that underlies classification, it was found that employing Deep Learning models was the most sophisticated method for getting the desired outcomes (also known as deep learning models). We experimented with many different mathematical models, both with and without the application of Learning Algorithms. However, we concluded that the depth and quality of activation that was made available by pre-trained models did not meet up. Consequently, we merged our mathematical expertise and developed a model known as a Dense Convolutional Network, which offered an accuracy of more than 86.6 percent.

2. LITERATURE SURVEY

Hameed et al. [3] implemented using a hybrid approach i.e., using deep convolution neural network and error-correcting output codes (ECOC) support vector machine (SVM). The proposed scheme is designed, implemented, and tested to classify skin lesion image into one of five categories, i.e., healthy, acne, eczema, benign, or malignant melanoma. Experiments were performed on 9,144 images obtained from different sources. AlexNET, a pre-trained CNN model was used to extract the features. For classification, the ECOC SVM classifier was used. Using ECOC SVM, the overall accuracy achieved is 86.21%. 10-fold cross validation technique was used to avoid overfitting. The results indicate that features obtained from the convolutional neural network can enhance the classification performance of multiple skin lesions.

Aldhyani et al. [4] proposed a CNN-based model with efficient utilization of kernels and activation functions. The proposed model has shown a remarkable class-wise (seven classes) accuracy and overall accuracy of 97.85% on the test dataset with fewer parameters than is standard (172,363). The proposed model can also be used for disease classification with a dataset that has more classes. The model still

has room for more accurate prediction of benign keratosis-like lesions, melanoma, and melanocytic nevi classes of skin lesions.

Vakili et al. [5] focused on primary skin lesion classification, particularly early-stage detection, and present a deep learning approach to classify images containing skin lesions, macule, nodule, papule, plaque pustule, wheal, and bulla. This framework applied deep learning techniques for classifying such images into seven classes covering the types of lesions. This work performed experiments on pre-trained deep convolutional neural network models to find the most accurate one. The result showed that the pre-trained model ResNet-50 after the training and testing can achieve satisfactory accuracy of 85.95%.

Iqbal et al. [6] developed, implemented, and calibrated an advanced deep learning model in the context of automated multi-class classification of skin lesions. The proposed Deep Convolutional Neural Network (DCNN) model is carefully designed with several layers, and multiple filter sizes, but fewer filters and parameters to improve efficacy and performance. Dermoscopic images are acquired from the International Skin Imaging Collaboration databases (ISIC-17, ISIC-18, and ISIC-19) for experiments. The experimental results of the proposed DCNN approach are presented in terms of precision, sensitivity, specificity, and other metrics. Specifically, it attains 94 % precision, 93 % sensitivity, and 91 % specificity in ISIC-17. It is demonstrated by the experimental results that this proposed DCNN approach outperforms state-of-the-art algorithms, exhibiting 0.964 area under the receiver operating characteristics (AUROC) in ISIC-17 for the classification of skin lesions and can be used to assist dermatologists in classifying skin lesions. As a result, this proposed approach provides a novel and feasible way for automating and expediting the skin lesion classification task as well as saving effort, time, and human life.

Chaturvedi et al. [7] proposed an automated computer-aided diagnosis system for multi-class skin (MCS) cancer classification with an exceptionally high accuracy. The proposed method outperformed both expert dermatologists and contemporary deep learning methods for MCS cancer classification. This work performed fine-tuning over seven classes of HAM10000 dataset and conducted a comparative study to analyse the performance of five pre-trained convolutional neural networks (CNNs) and four ensemble models. The maximum accuracy of 93.20% for individual model amongst the set of models whereas maximum accuracy of 92.83% for ensemble model is reported in this paper. This framework proposed use of ResNeXt101 for the MCS cancer classification owing to its optimized architecture and ability to gain higher accuracy.

Anjum et al. [8] proposed the ensemble CNN models for skin lesion detection. In the localization method, ONNX and squeeze Net model is used as a backbone of the YOLOv2 model. The configuration parameters of the segmentation model are selected after the extensive experiment for accurate lesion segmentation. The segmentation method achieves Global Accuracy of 0.93, 0.95 on ISBI 2017, and ISBI 2018 respectively. The skin lesion classification is performed by applying ResNet-18 model and deep features are extracted by cross entropy activation function. Later, extracted features vectors are enhanced by using ACO method. The hybrid classification approach provided good classification results compared to the recent existing work.

Anand et al. [9] proposed a transfer learning-based model with help of pre-trained Xception model. The Xception model was modified by adding layers such as one pooling layer, two dense layers and one dropout layer. A new Fully Connected (FC) layer changed the original Fully Connected (FC) layer with seven skin disease classes. The proposed model has been evaluated on a HAM10000 dataset with large class imbalances. The data augmentation techniques were applied to overcome the unbalancing in the dataset. The new results showed that the model has attained an accuracy of 96.40% for classifying skin diseases. The proposed model works best on Benign Keratosis and the values of precision, sensitivity

and F1 score are 99%, 97% and 0.98 respectively. This method can provide patients and doctors with a good notion of whether medical assistance is required, thus, avoiding undue stress and false alarms.

Srinivasu et al. [10] proposed a computerized process of classifying skin disease through deep learning based MobileNet V2 and Long Short-Term Memory (LSTM). The MobileNet V2 model proved to be efficient with a better accuracy that can work on lightweight computational devices. The proposed model is efficient in maintaining stateful information for precise predictions. A grey-level co-occurrence matrix is used for assessing the progress of diseased growth. The performance has been compared against other state-of-the-art models such as Fine-Tuned Neural Networks (FTNN), Convolutional Neural Network (CNN), Very Deep Convolutional Networks for Large-Scale Image Recognition developed by Visual Geometry Group (VGG), and convolutional neural network architecture that expanded with few changes.

Shanthi et al. [11] utilized the Convolutional Neural Network (CNN) used in this paper around 11 layers viz., Convolution Layer, Activation Layer, Pooling Layer, Fully Connected Layer and Soft-Max Classifier. Images from the DermNet database are used for validating the architecture. The database comprised all types of skin diseases out of which we have considered four different types of skin diseases like Acne, Keratosis, Eczema herpeticum, Urticaria with each class containing around 30 to 60 different samples. The challenge in automating the process includes the variation of skin tones, location of the disease, specifications of the image acquisition system etc., The proposed CNN Classifier results in an accuracy of 98.6% to 99.04%.

Allugunti et al. [12] shown a deep learning technique for reliably diagnosing the type of melanoma present at a preliminary phase. The proposed model makes a distinction between lesion maligna, superficial spreading, and nodular melanoma. This permits the early diagnosis of the virus and the quick isolation and therapy necessary to stop the transmission of infection further. Deep learning (DL) and the standard non-parametric machine learning method are exemplified in the deep layer topologies of the convolutional neural network (CNN), which are neural network algorithms. The effectiveness of a CNN classifier was evaluated using data retrieved from the website <https://dermnetnz.org/>. The outcomes of the experiments show that the proposed method is superior in terms of diagnostic accuracy compared to the methodologies that are currently considered state of the art.

3. PROPOSED SYSTEM

In this project we are using CNN (convolution neural networks) to classify skin diseases from images as CNN gain lots of success and popularity in the field of image classification. To train CNN we have used skin disease dataset which contains 9 different types of diseases such as 'Actinic Keratosis', 'Basal Cell Carcinoma', 'Dermatofibroma', 'Melanoma', 'Nevus', 'Pigmented Benign Keratosis', 'Seborrheic Keratosis', 'Squamous Cell Carcinoma' and 'Vascular Lesion'. After training CNN algorithm, we can upload any test image then CNN will detect and classify disease from that image. Fig. 1 shows the block diagram of the proposed system.

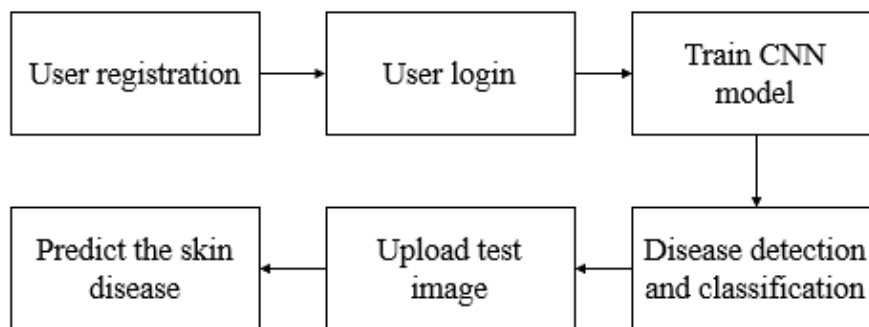

Fig. 1: Block diagram of proposed system.

3.1 User registration

This module is used for user registration. In this module user must upload the username, password, contact number, email ID, address. After entering the details then press the register button.

3.2 User login

In this module user must enter their username and password to access the account.

3.3 Train CNN model

DL-CNN

According to the facts, training and testing of any deep neural network or transfer learning involves in allowing every source image via a succession of convolution layers by a kernel or filter, rectified linear unit (ReLU), max pooling, fully connected layer and utilize SoftMax layer with classification layer to categorize the objects with probabilistic values ranging from [0,1].

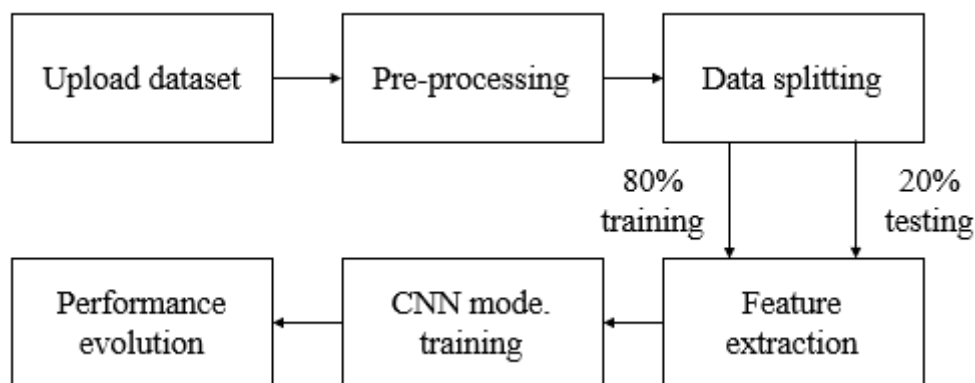

Fig. 2: Proposed system for DL-CNN model training.

Convolution layer as is the primary layer to extract the features from a source image and maintains the relationship between pixels by learning the features of image by employing tiny blocks of source data. It's a mathematical function which considers two inputs like source image $I(x, y, d)$ where x and y denotes the spatial coordinates i.e., number of rows and columns. d is denoted as dimension of an image (here $d = 3$, since the source image is RGB) and a filter or kernel with similar size of input image and can be denoted as $F(k_x, k_y, d)$.

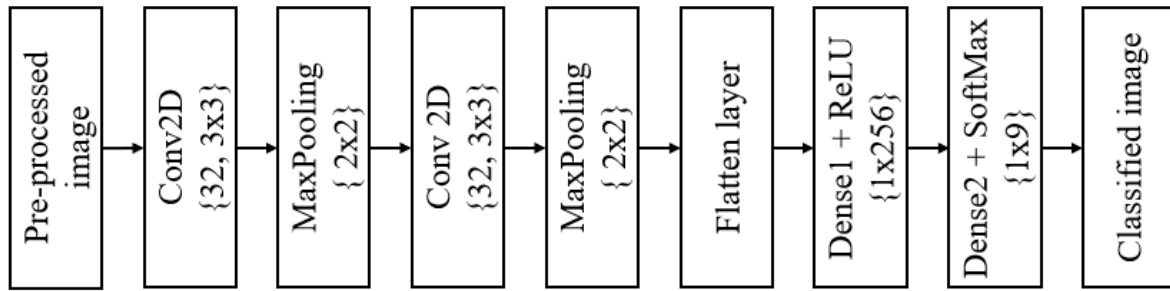

Fig. 3: CNN architecture.

The output obtained from convolution process of input image and filter has a size of $C((x - k_x + 1), (y - k_y + 1), 1)$, which is referred as feature map. Let us assume an input image with a size of 5×5 and the filter having the size of 3×3 . The feature map of input image is obtained by multiplying the input image values with the filter values.

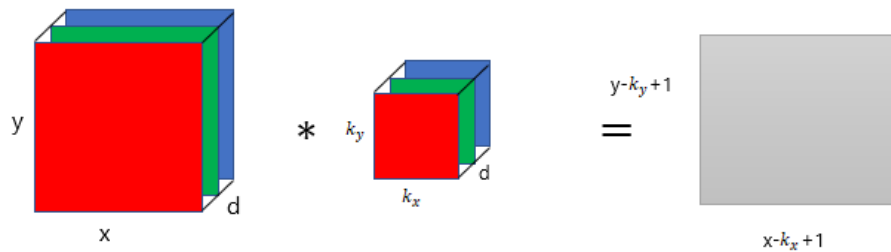

Fig. 4: Representation of convolution layer process.

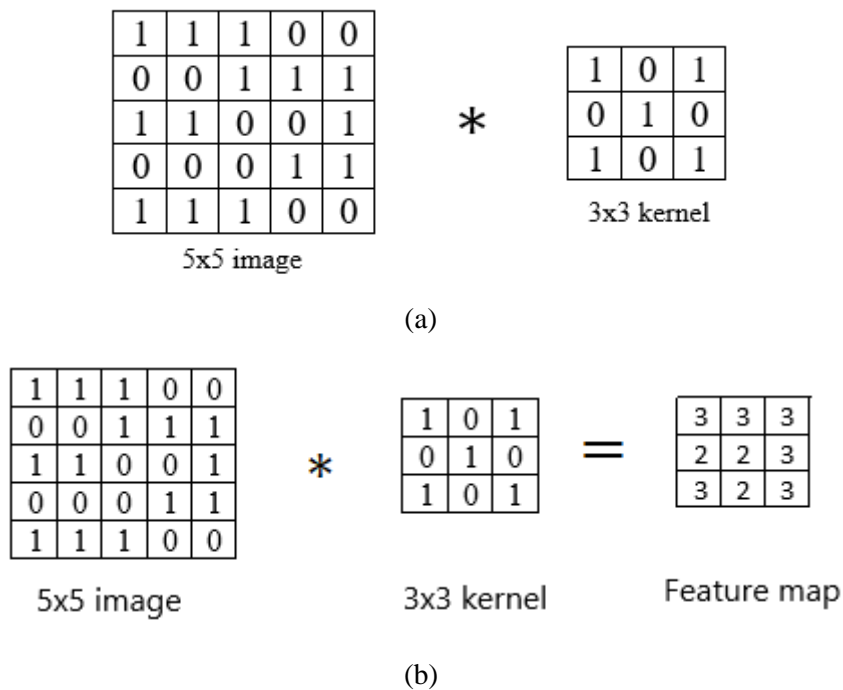

Fig. 5: Example of convolution layer process (a) an image with size 5×5 is convolving with 3×3 kernel (b) Convolved feature map.

3.3.1 ReLU layer

Networks that utilize the rectifier operation for the hidden layers are cited as rectified linear unit (ReLU). This ReLU function $\mathcal{G}(\cdot)$ is a simple computation that returns the value given as input directly if the value of input is greater than zero else returns zero. This can be represented as mathematically using the function $\max(\cdot)$ over the set of 0 and the input x as follows:

$$\mathcal{G}(x) = \max\{0, x\}$$

3.3.2 Max pooling layer

This layer mitigates the number of parameters when there are larger size images. This can be called as subsampling or down sampling that mitigates the dimensionality of every feature map by preserving the important information. Max pooling considers the maximum element from the rectified feature map.

3.3.3 Softmax classifier

Generally, as seen in the above picture softmax function is added at the end of the output since it is the place where the nodes are meet finally and thus, they can be classified. Here, X is the input of all the models and the layers between X and Y are the hidden layers and the data is passed from X to all the layers and Received by Y . Suppose, we have 10 classes, and we predict for which class the given input belongs. So, for this what we do is a lot each class with a particular predicted output. Which means that we have 10 outputs corresponding to 10 different classes and predict the class by the highest probability it has.

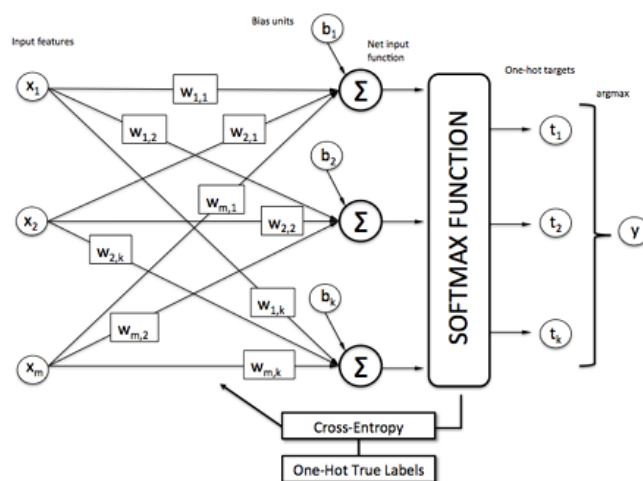

Fig. 6: Classification using SoftMax classifier.

In Fig. 7, and we must predict what the object that is present in the picture. In the normal case, we predict whether the crop is A. But in this case, we must predict what the object that is present in the picture. This is the place where softmax comes in handy. As the model is already trained on some data. So, as soon as the picture is given, the model processes the pictures, sends it to the hidden layers and then finally send to softmax for classifying the picture.

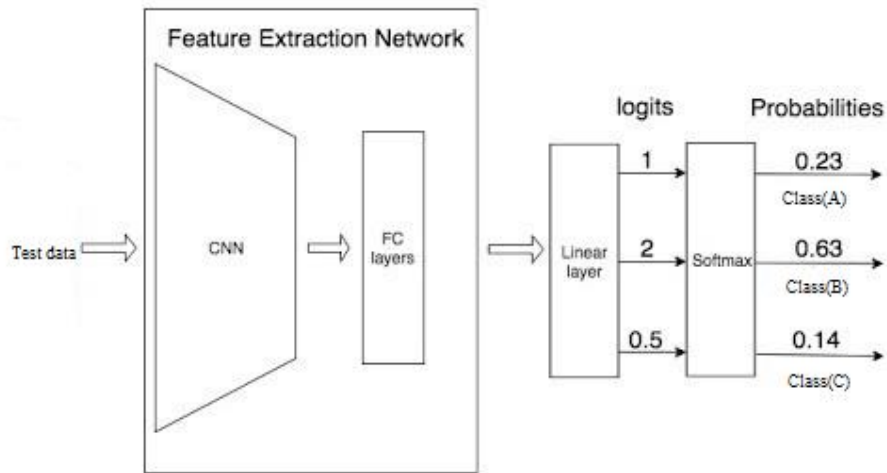

Fig. 7: Example of SoftMax classifier.

The softmax uses a One-Hot encoding Technique to calculate the cross-entropy loss and get the max. One-Hot Encoding is the technique that is used to categorize data. In the previous example, if softmax predicts that the object is class A then the One-Hot Encoding for:

Class A will be [1 0 0]

Class B will be [0 1 0]

Class C will be [0 0 1]

From the diagram, we see that the predictions are occurred. But generally, we don't know the predictions. But the machine must choose the correct predicted object. So, for machines to identify an object correctly, it uses a function called cross-entropy function.

So, we choose more similar values by using the below cross-entropy formula.

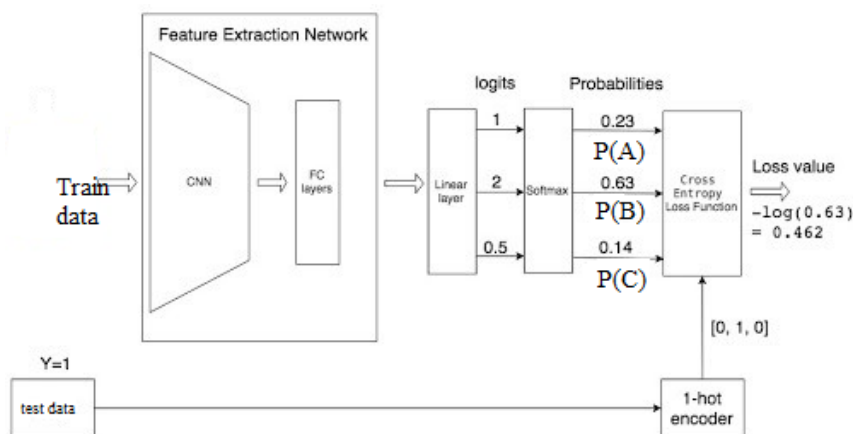

Fig. 8: Example of SoftMax classifier with test data.

In the above example we see that 0.462 is the loss of the function for class specific classifier. In the same way, we find loss for remaining classifiers. The lowest the loss function, the better the prediction is. The mathematical representation for loss function can be represented as: -

$$LOSS = np.sum(-Y * np.log(Y_pred))$$

4. RESULTS AND DISCUSSION

B Kishore: MULTI-CLASS CLASSIFICATION OF SKI DISEASE

In below screen I am showing dataset used in this project

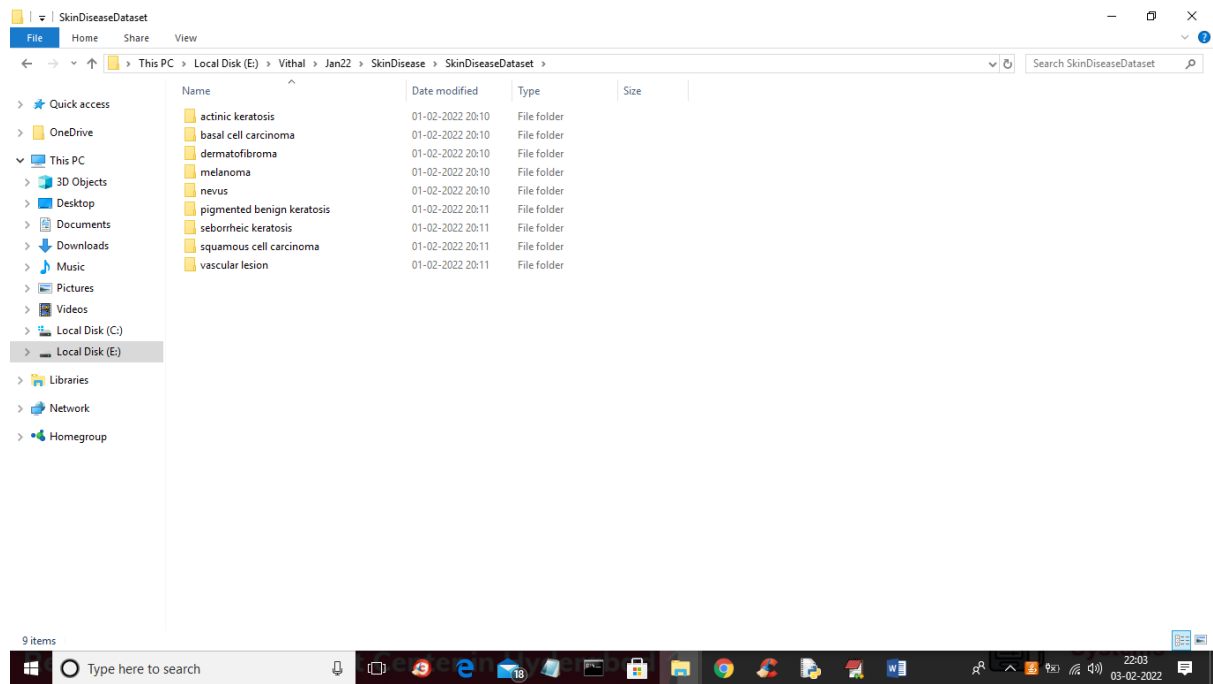

In the above screen 9 different folders are there with different diseases names and just enter any folder to see that disease images. You can see below screen

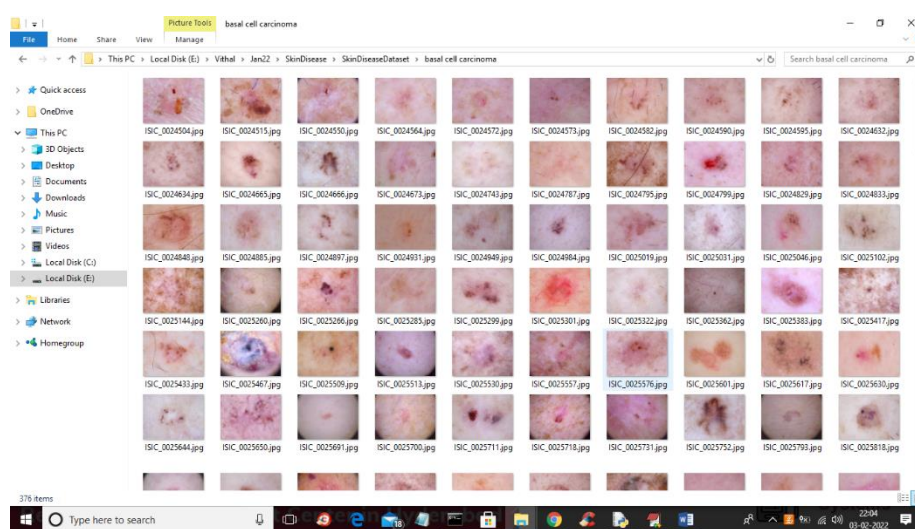

We are using above images to train CNN and below screen showing CNN code for training.

```

testtrain.py - E:\VihajJan22\SkinDisease\testtrain.py (3.7.0)
File Edit Format Run Options Window Help
from sklearn.model_selection import train_test_split

path = 'SkinDiseaseDataset' #dataset path
labels = []
X = []
Y = []

def getID(name):
    index = 0
    for i in range(len(labels)):
        if labels[i] == name:
            index = i
            break
    return index

for root, dirs, directory in os.walk(path):
    for j in range(len(directory)):
        name = os.path.basename(root)
        if name not in labels:
            labels.append(name)
    print(labels)

for root, dirs, directory in os.walk(path): #looping all images from dataset and then reading each image
    for j in range(len(directory)):
        name = os.path.basename(root)
        print(name+" "+root+" "+directory[j])
        if "Thumb.jpg" not in directory[j]: #read the image
            img = cv2.imread(root+" "+directory[j]) #read the image
            img = cv2.resize(img, (32,32)) #resize image
            imgarr = np.array(img) #convert image to numpy array
            imgarr = imgarr.reshape(32,32,3) #convert image as color image
            X.append(imgarr) #add image to X array
            Y.append(getID(name)) #add id of disease name as class label to Y array

X = np.asarray(X)
Y = np.asarray(Y)
np.save('model/X.txt',X)
np.save('model/Y.txt',Y)

```

In above code read red colour comments to know about reading and processing images and then saving to X and Y array and in below screen we can CNN is getting training with X and Y array values

```

news.py - E:\VihajJan22\SkinDiseaseApp\news.py (3.7.0)
File Edit Format Run Options Window Help
indices = np.arange(X.shape[0])
np.random.shuffle(indices)
X = X[indices]
Y = Y[indices]
Y = to_categorical(Y)
X_train, X_test, y_train, y_test = train_test_split(X, Y, test_size=0.2)
if os.path.exists('model/model.json'):
    with open('model/model.json', "r") as json_file:
        loaded_model_json = json_file.read()
        classifier = model_from_json(loaded_model_json)
        json_file.close()
        classifier.load_weights("model/model_weights.h5")
        classifier.make_predict_function()
else:
    classifier = Sequential()
    #defining convolution neural network layer with 32 layers to filter dataset features 32 times and then max pooling will collect all important features
    classifier.add(Convolution2D(32, 3, 3, input_shape = (32, 32, 3), activation = 'relu'))
    #pooling layer to collect filtered features
    classifier.add(MaxPooling2D(pool_size = (2, 2)))
    #defining another layer with 32 filters
    classifier.add(Convolution2D(32, 3, 3, activation = 'relu'))
    classifier.add(MaxPooling2D(pool_size = (2, 2)))
    classifier.add(Flatten())
    classifier.add(Dense(output_dim = 256, activation = 'relu'))
    classifier.add(Dense(output_dim = y_train.shape[1], activation = 'softmax'))
    print(classifier.summary())
    #now compiling the model
    classifier.compile(optimizer = 'adam', loss = 'categorical_crossentropy', metrics = ['accuracy'])
    #now training CNN model with X and Y array data
    hist = classifier.fit(X, Y, batch_size=8, epochs=50, shuffle=True, verbose=2, validation_data=(X_test, y_test))
    classifier.save_weights('model/cnn_model_weights.h5')
    model_json = classifier.to_json()
    with open('model/cnn_model.json', "w") as json_file:
        json_file.write(model_json)
    json_file.close()
    print(classifier.summary())
    cnn_algorithm = classifier
    conf_matrix, output = CNNtestPrediction("CNN Skin Disease Classification",classifier,X_test,y_test)
    context = {'data':output}
    plt.figure(figsize = (6, 6))
    ax = sns.heatmap(conf_matrix, xticklabels = class_labels, yticklabels = class_labels, annot = True, cmap="viridis", fmt = "g");

```

In above code you can see we are defining Convolution Neural Network (CNN) object and then training with X and Y array values.

To run project double click on 'run.bat' file to start DJANGO web server and to get below screen

B Kishore: MULTI-CLASS CLASSIFICATION OF SKI DISEASE

```

C:\Windows\system32\cmd.exe
nvm of type is deprecated; in a future version of numpy, it will be understood as (type, (1,)) / '(1,)type'.
C:\Users\Admin\AppData\Local\Programs\Python\Python37\lib\site-packages\tensorflow\python\framework\dtypes.py:517: FutureWarning: Passing (type, 1) or 'iType' as a synonym of type is deprecated; in a future version of numpy, it will be understood as (type, (1,)) / '(1,)type'.
  np_uint8 = np.dtype(("uint8", np.int8, 1))
C:\Users\Admin\AppData\Local\Programs\Python\Python37\lib\site-packages\tensorflow\python\framework\dtypes.py:518: FutureWarning: Passing (type, 1) or 'iType' as a synonym of type is deprecated; in a future version of numpy, it will be understood as (type, (1,)) / '(1,)type'.
  np_uint16 = np.dtype(("uint16", np.int16, 1))
C:\Users\Admin\AppData\Local\Programs\Python\Python37\lib\site-packages\tensorflow\python\framework\dtypes.py:519: FutureWarning: Passing (type, 1) or 'iType' as a synonym of type is deprecated; in a future version of numpy, it will be understood as (type, (1,)) / '(1,)type'.
  np_uint32 = np.dtype(("uint32", np.int32, 1))
C:\Users\Admin\AppData\Local\Programs\Python\Python37\lib\site-packages\tensorflow\python\framework\dtypes.py:520: FutureWarning: Passing (type, 1) or 'iType' as a synonym of type is deprecated; in a future version of numpy, it will be understood as (type, (1,)) / '(1,)type'.
  np_uint64 = np.dtype(("uint64", np.int64, 1))
C:\Users\Admin\AppData\Local\Programs\Python\Python37\lib\site-packages\tensorflow\python\framework\dtypes.py:525: FutureWarning: Passing (type, 1) or 'iType' as a synonym of type is deprecated; in a future version of numpy, it will be understood as (type, (1,)) / '(1,)type'.
  np_resource = np.dtype(("resource", np.ubyte, 1))
C:\Users\Admin\AppData\Local\Programs\Python\Python37\lib\site-packages\tensorboard\compat\tensorflow_stub\dtypes.py:541: FutureWarning: Passing (type, 1) or 'iType' as a synonym of type is deprecated; in a future version of numpy, it will be understood as (type, (1,)) / '(1,)type'.
  np_int8 = np.dtype(("int8", np.int8, 1))
C:\Users\Admin\AppData\Local\Programs\Python\Python37\lib\site-packages\tensorboard\compat\tensorflow_stub\dtypes.py:542: FutureWarning: Passing (type, 1) or 'iType' as a synonym of type is deprecated; in a future version of numpy, it will be understood as (type, (1,)) / '(1,)type'.
  np_uint8 = np.dtype(("uint8", np.uint8, 1))
C:\Users\Admin\AppData\Local\Programs\Python\Python37\lib\site-packages\tensorboard\compat\tensorflow_stub\dtypes.py:543: FutureWarning: Passing (type, 1) or 'iType' as a synonym of type is deprecated; in a future version of numpy, it will be understood as (type, (1,)) / '(1,)type'.
  np_int16 = np.dtype(("int16", np.int16, 1))
C:\Users\Admin\AppData\Local\Programs\Python\Python37\lib\site-packages\tensorboard\compat\tensorflow_stub\dtypes.py:544: FutureWarning: Passing (type, 1) or 'iType' as a synonym of type is deprecated; in a future version of numpy, it will be understood as (type, (1,)) / '(1,)type'.
  np_uint16 = np.dtype(("uint16", np.uint16, 1))
C:\Users\Admin\AppData\Local\Programs\Python\Python37\lib\site-packages\tensorboard\compat\tensorflow_stub\dtypes.py:545: FutureWarning: Passing (type, 1) or 'iType' as a synonym of type is deprecated; in a future version of numpy, it will be understood as (type, (1,)) / '(1,)type'.
  np_int32 = np.dtype(("int32", np.int32, 1))
C:\Users\Admin\AppData\Local\Programs\Python\Python37\lib\site-packages\tensorboard\compat\tensorflow_stub\dtypes.py:550: FutureWarning: Passing (type, 1) or 'iType' as a synonym of type is deprecated; in a future version of numpy, it will be understood as (type, (1,)) / '(1,)type'.
  np_resource = np.dtype(("resource", np.ubyte, 1))
System check identified no issues (0 silenced).

You have 15 unapplied migration(s). Your project may not work properly until you apply the migrations for app(s): admin, auth, contenttypes, sessions.
Run 'python manage.py migrate' to apply them.
February 03, 2022 - 22:14:33
Django version 2.1.7, using settings 'SkinDisease.settings'
Starting development server at http://127.0.0.1:8000/
Quit the server with CTRL-BREAK.

```

In above screen DJANGO server started and now open browser and enter URL as <http://127.0.0.1:8000/index.html> and press enter key to get below screen



In above screen click on 'Register Here' link to get below signup screen

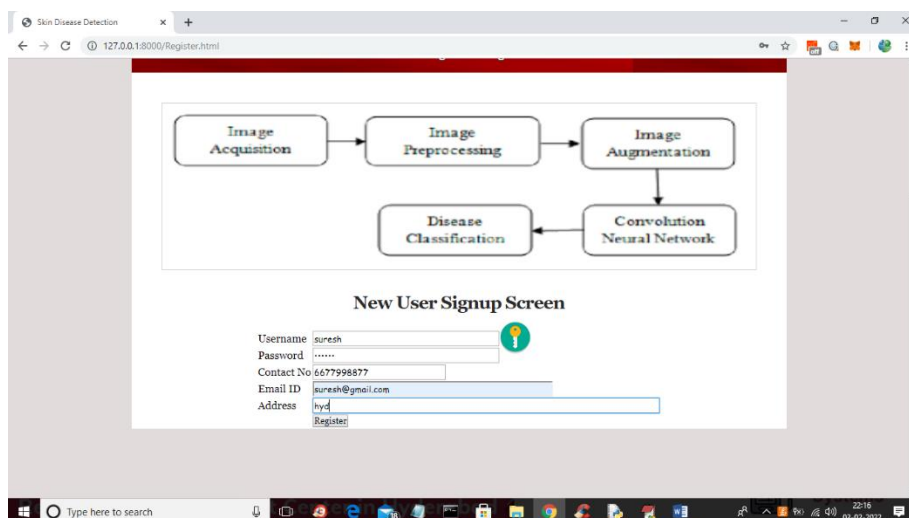

In above screen user is enter signup details and then press ‘Register’ button to complete signup process and to get below output

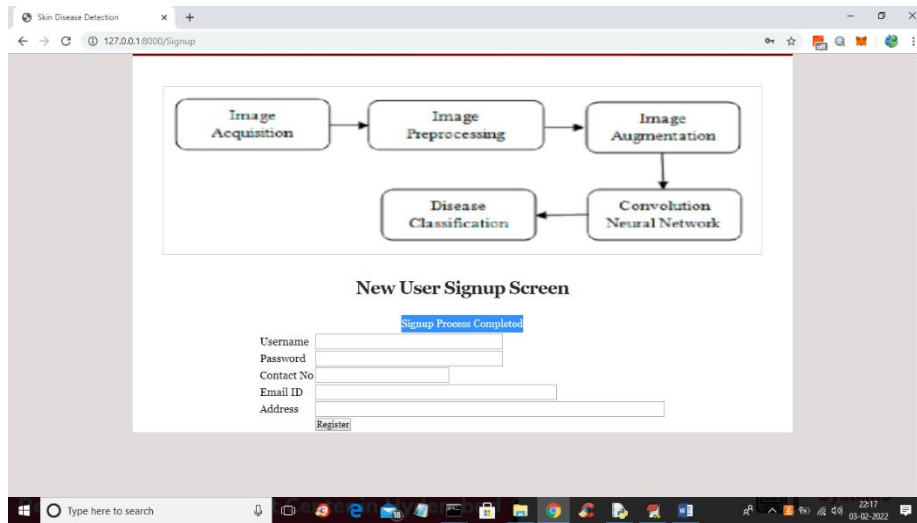

In above screen in blue colour text we can see signup process completed and now click on ‘Login’ link to get below screen

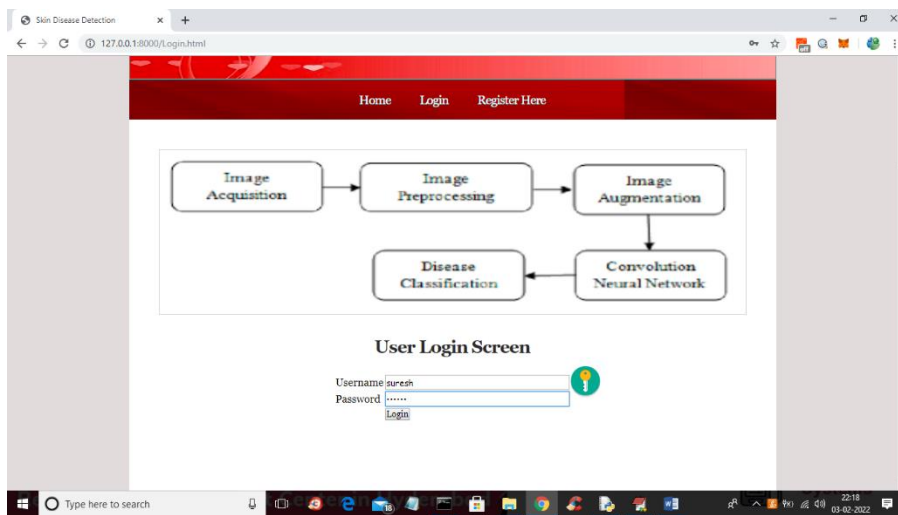

In above screen user is login and then click on ‘Login’ button to get below screen

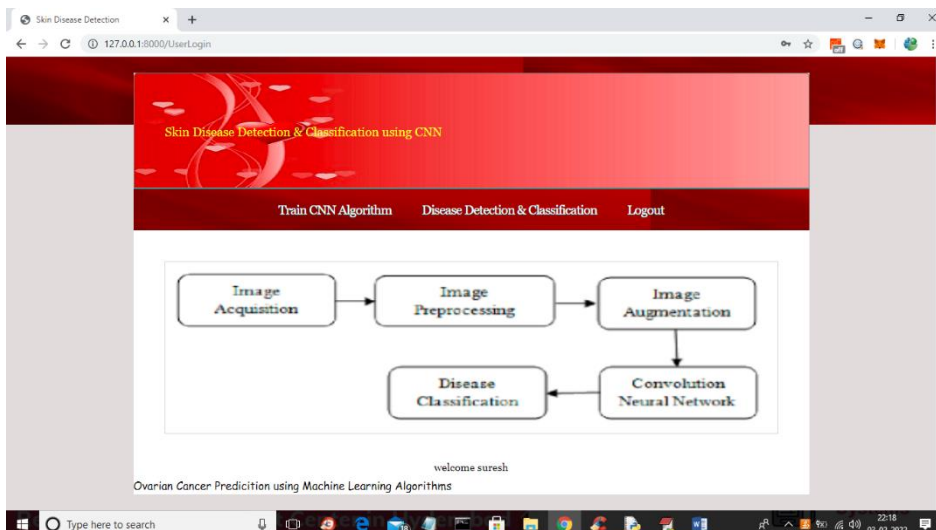

B Kishore: MULTI-CLASS CLASSIFICATION OF SKI DISEASE

In above screen user can click on 'Train CNN Algorithm' link to train CNN and to get below output

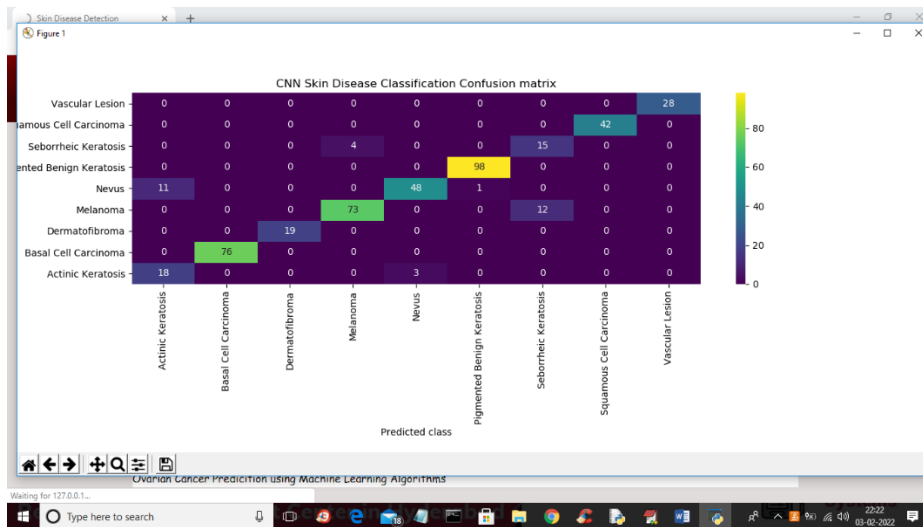

In above CNN confusion matrix graph we can prediction on test data and in above graph x-axis represents predicted disease names and y-axis represents original test classes and in above all values in diagonal boxes are the correct prediction and value > 0 which are not in diagonal are the wrong prediction and we can see only few records are wrongly predicted. Now close above graph to get below CNN accuracy

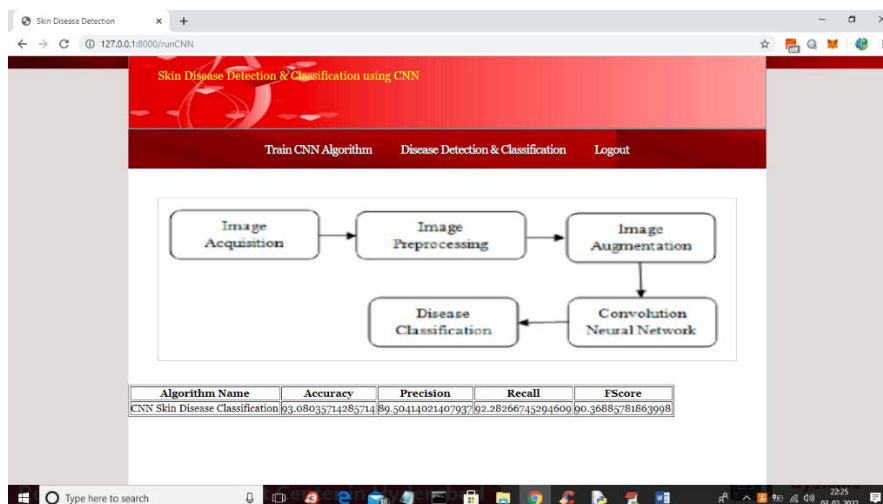

In above screen we got CNN accuracy as 93% and in below screen we can see CNN architecture

```

C:\Windows\system32\cmd.exe
[03/Feb/2022 21:19:46] "GET /DiseasePrediction.html HTTP/1.1" 200 1810
WARNING:tensorflow:From C:\Users\Admin\AppData\Local\Programs\Python\Python37\lib\site-packages\keras\backend\tensorflow_backend.py:4878: The name tf.nn.max_pool is deprecated. Please use tf.nn.max_pool2d instead.
[03/Feb/2022 21:20:04] "POST /DiseasePredictionAction HTTP/1.1" 200 1810
[03/Feb/2022 22:15:32] "GET /index.html HTTP/1.1" 200 834
[03/Feb/2022 22:15:34] "GET /static/images/investor_398 HTTP/1.1" 304 0
[03/Feb/2022 22:16:26] "GET /Register.html HTTP/1.1" 200 3291
1 Record Inserted
[03/Feb/2022 22:16:45] "POST /Signup HTTP/1.1" 200 3315
[03/Feb/2022 22:18:00] "GET /Login.html HTTP/1.1" 200 2834
[03/Feb/2022 22:18:17] "GET /Login.html HTTP/1.1" 200 2834
[03/Feb/2022 22:18:25] "POST /UserLogin HTTP/1.1" 200 1849
[0 0 ... 8 8 8]
Model: "sequential_1"
Layer (type) Output Shape Param #
-----
conv2d_1 (Conv2D) (None, 38, 38, 32) 896
max_pooling2d_1 (MaxPooling2D) (None, 15, 15, 32) 0
conv2d_2 (Conv2D) (None, 13, 13, 32) 9248
max_pooling2d_2 (MaxPooling2D) (None, 6, 6, 32) 0
flatten_1 (Flatten) (None, 1152) 0
dense_1 (Dense) (None, 256) 295168
dense_2 (Dense) (None, 9) 2313
-----
Total params: 307,625
Trainable params: 307,625
Non-trainable params: 0
None
[03/Feb/2022 22:22:54] "GET /runCNN HTTP/1.1" 200 1417
    
```

In above CNN architecture we have designed multiple layers with different image sizes such as 30 X 30, 15 X 15 etc. Now go back to output application and then click on 'Disease Detection & Classification' link to get below output

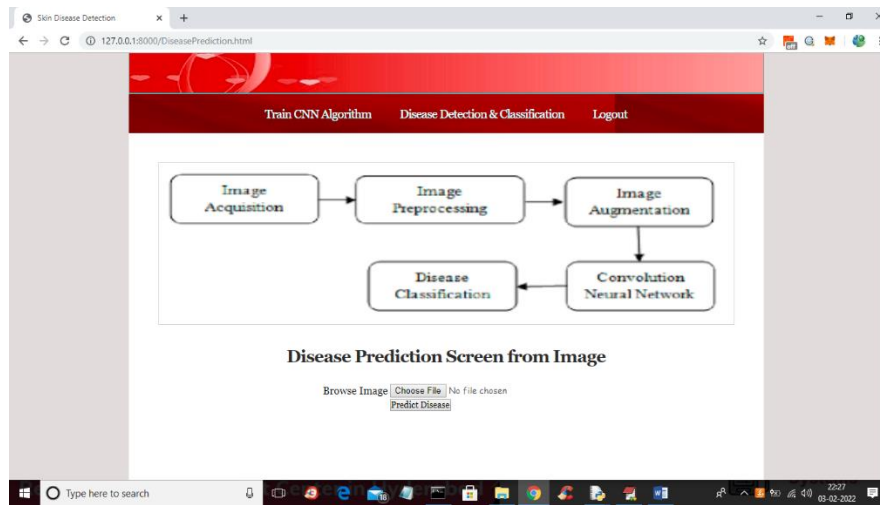

In above screen click on 'Choose File' button to upload skin diseases images from 'testImages' folder and then click on 'Predict Disease' button to classify disease

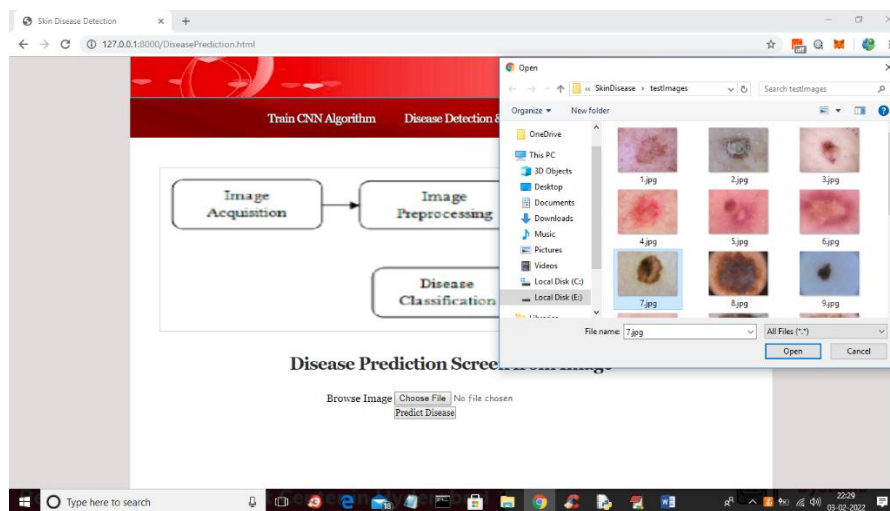

In above screen selecting and uploading '7.jpg' and then click on 'Open' button to load image and then click on 'Predict Disease' button to get below output



B Kishore: MULTI-CLASS CLASSIFICATION OF SKI DISEASE

In above screen in blue colour text we can see CNN classify disease on image as 'Melanoma' and similarly you can upload and test remaining images

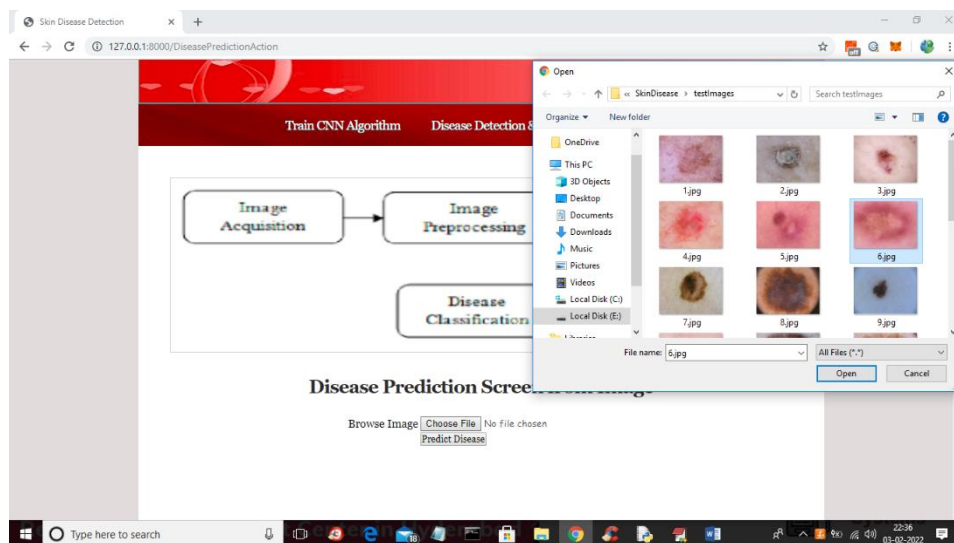
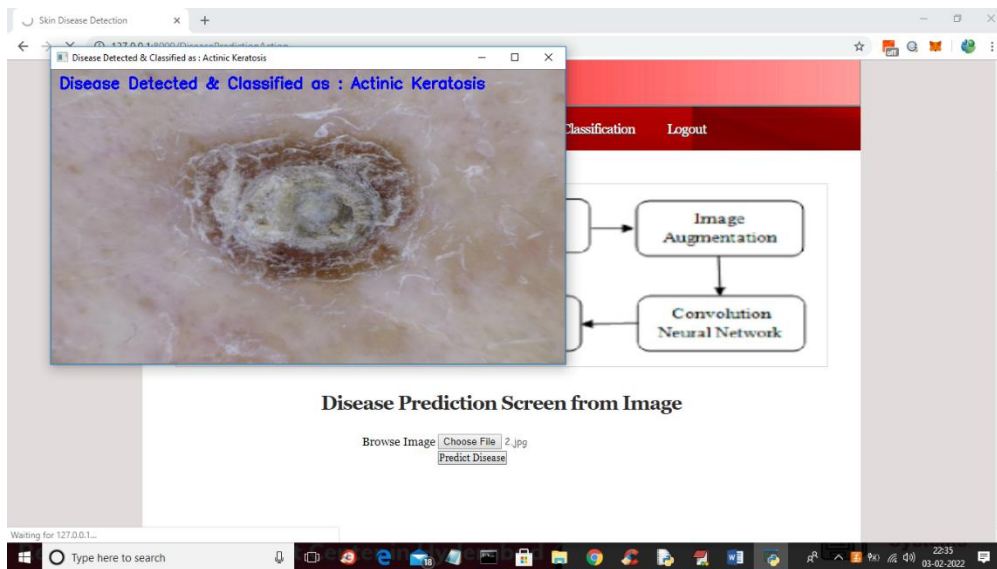
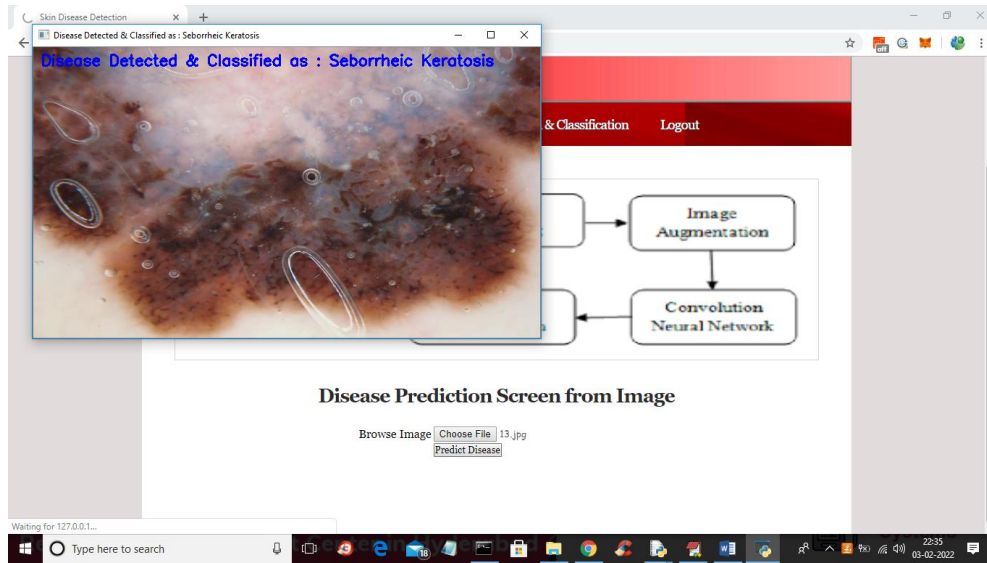

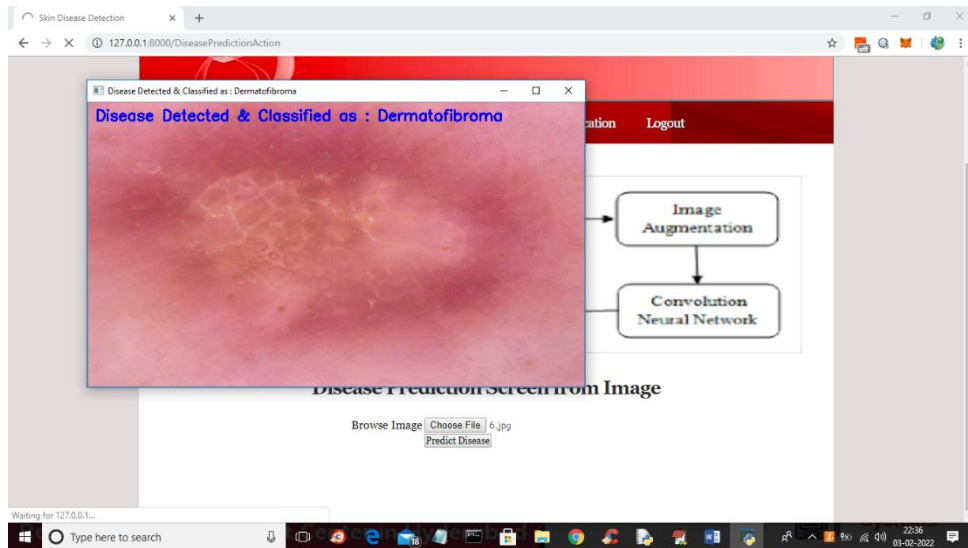

5. CONCLUSION AND FUTURE WORK

In this framework, deep learning convolution neural network (DL-CNN) was designed for the multi-class classification of skin cancer in order to archive the system's maximum efficiency and contribute to this study. Therefore, the findings of the study may be successfully applied to the categorization of all nine distinct forms of skin cancer. In future this work, further enhance to apply the re-enforcement learning for accurately classify the skin lesion.

REFERENCES

- [1] Zhang Ce, Xin Pan, Huapeng Li, Gardiner A, Sargent I, Jonathon S Hare, et al. A hybrid MLP-CNN classifier for very fine resolution remotely sensed image classification. *Isprs Journal of Photogrammetry and Remote Sensing*. 2017; 140:133-144.
- [2] Bi Lei, Jinman Kim, Euijoon Ahn, Feng D. Automatic Skin Lesion Analysis using Large-scale Dermoscopy Images and Deep Residual Networks. *ArXiv abs*. 2017; 1703:04197.
- [3] N. Hameed, A. M. Shabut and M. A. Hossain, "Multi-Class Skin Diseases Classification Using Deep Convolutional Neural Network and Support Vector Machine," 2018 12th International Conference on Software, Knowledge, Information Management & Applications (SKIMA), 2018, pp. 1-7, doi: 10.1109/SKIMA.2018.8631525.
- [4] Aldhyani, T.H.H.; Verma, A.; Al-Adhaileh, M.H.; Koundal, D. Multi-Class Skin Lesion Classification Using a Lightweight Dynamic Kernel Deep-Learning-Based Convolutional Neural Network. *Diagnostics* 2022, 12, 2048. <https://doi.org/10.3390/diagnostics12092048>.
- [5] N. Vakili, W. Krathu, and N. Laomaneerattanaporn. 2021. Multi-Class Primary Morphology Lesions Classification Using Deep Convolutional Neural Network. In *The 12th International Conference on Advances in Information Technology (IAIT2021)*. Association for Computing Machinery, New York, NY, USA, Article 9, 1–7. <https://doi.org/10.1145/3468784.3468887>
- [6] I. Iqbal, M. Younus, K. Walayat, M. U. Kakar, J. Ma, Automated multi-class classification of skin lesions through deep convolutional neural network with dermoscopic images, *Computerized Medical Imaging and Graphics*, Volume 88, 2021, 101843, ISSN 0895-6111, <https://doi.org/10.1016/j.compmedimag.2020.101843>.
- [7] Chaturvedi, S.S., Tembhurne, J.V. & Diwan, T. A multi-class skin Cancer classification using deep convolutional neural networks. *Multimed Tools Appl* 79, 28477–28498 (2020).

<https://doi.org/10.1007/s11042-020-09388-2>.

- [8] M. A. Anjum, J. Amin, M. Sharif, H. U. Khan, M. S. A. Malik and S. Kadry, "Deep Semantic Segmentation and Multi-Class Skin Lesion Classification Based on Convolutional Neural Network," in *IEEE Access*, vol. 8, pp. 129668-129678, 2020, doi: 10.1109/ACCESS.2020.3009276.
- [9] Anand, V., Gupta, S., Koundal, D., Nayak, S. R., Nayak, J., & Vimal, S. (2022). Multi-class Skin Disease Classification Using Transfer Learning Model. *International Journal on Artificial Intelligence Tools*, 31(02), 2250029.
- [10] Srinivasu PN, SivaSai JG, Ijaz MF, Bhoi AK, Kim W, Kang JJ. Classification of Skin Disease Using Deep Learning Neural Networks with MobileNet V2 and LSTM. *Sensors*. 2021; 21(8):2852. <https://doi.org/10.3390/s21082852>.
- [11] T. Shanthi, R.S. Sabeenian, R. Anand, Automatic diagnosis of skin diseases using convolution neural network, *Microprocessors and Microsystems*, Volume 76, 2020, 103074, ISSN 0141-9331, <https://doi.org/10.1016/j.micpro.2020.103074>.
- [12] Allugunti, V. R. (2022). A machine learning model for skin disease classification using convolution neural network. *International Journal of Computing, Programming and Database Management*, 3(1), 141-147.