

IOT-ENABLED AUTOMATED PILL REMINDER FOR STREAMLINED MEDICINE MANAGEMENT AND PATIENT ADHERENCE

Konatham Priyanka¹, Akula Rajini¹, Bandari Srilekha¹

¹Department of Electronics and Communication Engineering

¹Sree Dattha Group of Institutions, Sheriguda, Hyderabad, Telangana

ABSTRACT

People of all ages who are taking medication for illnesses, cosmetic purposes, or who need to take supplements because of faults are a familiar sight in today's generation. But because of their busy schedules, people frequently forget to take their medications. This is particularly true for the elderly and those with memory problems. Therefore, an automated pill reminder can be employed for this. Internally, this gadget has an RTC timer and an IoT module. Externally, it has an LCD display and audio prompts. As a central hub, the wireless IoT server-based Android app will enable us to remind customers through notifications, making it simple for them to monitor and adjust their prescription schedules from a distance. The Automatic Medicine Pill Reminder is a complete and easily accessible solution for all users because to its integration of user-friendly interfaces and cutting-edge IoT capabilities. It seeks to facilitate medication administration, encourage adherence to recommended regimens, and eventually improve the quality of healthcare.

Keywords: Automatic, Medicine, Pill Reminder, Smart Technology, Monitoring, Dosage, Medication Management, Elderly Care, Patient Support, Remote Monitoring, Health Tracking, Sensor Technology.

1. INTRODUCTION

Currently, worldwide aging and regularity of persistent diseases are flatterer a broad concern. Numerous countries are undergoing hospital restructuring by reducing the number of hospital beds and escalating home healthcare, which is envisioned to perk up health care quality, has fascinated wide-ranging attention. In order to track the physical status of the elderly and, in the meanwhile, to keep them healthy, the proposed idea will be helpful. IOT expands the Internet into our everyday lives by wirelessly connecting various smart objects and will bring significant changes in the way we live and interact with smart devices. The new wave in the era of computing will be outside the sphere of the conventional desktop. Internet of Things (IOT) is a network where many of the objects that surround us will be networked in one form or another. By using this technology the health statistics of medication are observed. In this process of encryption the schedule data or doctor's prescription are sent to the pill box through a mobile app. The LEDs are placed for indication and buzzer for alarm alerts and reset button is used to count for medicine in cloud platforms. The existing techniques to the market for the reminder include a pill box. But this does not help in checking the medicine. This proposed idea is a valuable solution to the medical noncompliance problem. The innovation scheme to help patients keep track of their medicine consumption through a series LED alarm indicator signal and audio alarm indicator signals. In today's culture, most people keep busy with their everyday schedules. It is true that they prioritise their work over caring for their health. Blood pressure and other illnesses, such as diabetes, are becoming quite prevalent. For elderly folks, taking regular medications becomes exceedingly challenging. Sometimes younger people are dealing with the same issues. Since so

many individuals require ongoing assistance, it is not always possible to always remind them to take their medications as prescribed. There must be a centre that monitors patients for this reason. A smart medication reminder system is intended to assist elderly people in taking care of themselves by making sure they take their meds in the right quantity and at the right time. This is used to modern technology-based living. This technology will be useful in some way. Cell phones are best used for making calls, but they might also be used as a collection of embedded sensors to enable new services including social networks, environmental tracking, healthcare, and human services. The use of mobile devices is becoming increasingly important in today's medical care systems. IoT may be useful for tracking current events, and it may also be a practical and efficient paradigm for storing sensor device data in the cloud. The complete monitoring system will be controlled by an IoT-enabled device in this project, and an android application was created to assist patients by reminding them when to take their medications and other things. To remember patients, there are numerous mechanisms available, including alarms and reminders. The Pill Reminder will make it easier for consumers to take the proper prescription when they need it. In recent years, the integration of Internet of Things (IoT) technology into various aspects of daily life has revolutionized how we interact with and manage our environments. One area where IoT holds immense potential is in healthcare, particularly in the management of medication adherence. Medication non-adherence is a significant issue globally, leading to adverse health outcomes and increased healthcare costs. In response to this challenge, automatic medicine pill reminders leveraging IoT technology have emerged as a promising solution to improve medication adherence and patient outcomes.

PROBLEM STATEMENT

- **Medication Non-Adherence:** Develop a system that utilizes IoT and real-time clock (RTC) technologies to address the issue of medication non-adherence by providing timely reminders and monitoring drug administration.
- **Patient Safety:** Create a smart drug administration system that ensures patient safety by integrating IoT sensors to detect potential adverse reactions, ensuring the right medication is administered to the right patient at the right time.
- **Inventory Management:** Implement an IoT and RTC-based solution to track medication inventory in real-time, providing alerts for low stock levels and expiring drugs, improving efficiency in healthcare facilities.
- **Remote Monitoring:** Design a system allowing healthcare professionals to remotely monitor and adjust medication schedules based on patient conditions, enhancing personalized care and treatment outcomes.
- **Data Security and Privacy:** Develop a secure IoT and RTC-based platform that ensures the confidentiality and integrity of patient data, addressing concerns related to privacy and security in healthcare systems.
- **Integration with Electronic Health Records (EHR):** Integrate the smart drug administration system with EHR platforms to enhance data continuity, facilitate comprehensive patient care, and streamline healthcare workflows.
- **User-friendly Interface:** Design an intuitive and user-friendly interface for both healthcare providers and patients, promoting easy interaction with the smart drug administration system and minimizing the risk of errors.

IOT-ENABLED AUTOMATED PILL REMINDER FOR STREAMLINED MEDICINE MANAGEMENT AND PATIENT ADHERENCE

- **Power Efficiency:** Create an energy-efficient IoT and RTC solution to prolong the battery life of devices used in the smart drug administration system, ensuring continuous functionality without frequent replacements.

2. LITERATURE REVIEW

Savithaa. N et al (2021) had designed a smart medicine box which had an android application which is installed on the patient's smart phone. Through this application patients could view their prescriptions and get notifications regarding medicine intake. Medicine box is provided with different compartments. An LED on top of each section signify the right box. At any moment patient opens a mistaken section, a warning will occur with the help of Arduino. A WI-FI shield is attached to the Arduino board and this microcontroller picks up the data and sends it through WI-FI module. These compartments are opened or closed by servo motor by means of electrical signal arrived from Arduino microcontroller. The device is programmed with Arduino which is plugged with alarm and LED display. Smart medicine box attached with vital parameter measuring sensors is implemented with IoT technology. Doesn't recover special training for handling. It is a user-friendly device even elder patients can operate easily. The instructions are displayed in LCD display

K. Karthikeyan et al.(2021) A study suggested deploying a separate bot to oversee the administration of medications. The bot will move to the user's home and dispense the necessary medications in accordance with the user's preprogrammed orders.

Divya Sai. K et al (2021) had designed a medicine box where the schedule data/configuration data is sent to the pill box through IoT. The smart pill box contains Arduino MCU, LED display, LEDs, buzzer, buttons, Pulse Sensor and Temperature Sensor. The LED are used to display the commands in pill box by MCU. The Wi-Fi module is configured with IoT. The configuration data is send to the smart pillbox when the configuration is in ON mode. The concerned LED glow with buzzer at schedule time. It is cost efficient and user friendly as user can set time table of medicine by himself. Highly reliable and the product can be used for long time. It is easy to use and manufacture It also provides accurate result

Anandhapadmanaban .S et al (2020) used Peltier module which is imported into one of the compartments made for cold storage and other compartments left without Peltier for room temperature storage. According to medical adherence, box is splitted to store drugs to be taken thrice times in a day. The patient's vital signs namely body temperature and heart beat rate are sensed and sent via sensor probe. An additional switch is built to alert the preset guardian through GSM module when it is triggered by strangers or guardians at emergency situation. Cloud storage 4 assists doctors to analyze the patient's health graph and gain knowledge about the recovery or degradation of their patient's health. By these knowledge doctors easily prepare their treatment plan earlier for his/her patient

Rao, A. et.al.(2020) methodology of proposed system. An IoT-based programmable innovative medicine kit guides users/nurses to manage the precise medication at the correct time schedules through a unique alarm system that includes buzzers, mobile notifications, and LED signals on the equipment sections. The parts containing suitable tablets are unlocked at the prearranged time.

Nur Zulaikhah Nadzri et al (2020) designed the device in such a way that the user will set the time according to the medicine scheduled by the doctor by using the Blynk apps. Then, if the time is correct it will notify by 2 notification, LED and buzzer is on. Magnetic switch is used to detect the action of opening

and closing the iBox cover. LDR to detect the action of taking the medicine If the user takes the medicine, the data will be stored in the cloud and this is triggered by the reed switch

Latif, G. et al.(2020) proposed design After seeing so many of these cases the correct person must take the correct pill at the correct time, otherwise taking an incorrect one or not taking one at all may expose the patient to several dangerous situations, ranging from mild health issues up to death.

Harshitha V et al (2020) created an IoT device is designed to remind patients about their medication time. By using the GSM, the caretakers can be notified through smart phones. Sensors like IR sensor, camera, and RFID tags are used to count the number of pills inside a tray and whether medicines has been taken properly These are interfaced with Arduino UNO micro-controller. The RFID stickers fastened on each tablet sheet will be scanned by using the RFID, camera and IR sensor. The sensors will be giving the count of pills inside the box periodically for every 5 to 6 hours. The timings for the intake of medicines by the patient will be set using RTC. By using RFID tags the pills which are taken can be identified, whether the patient has taken correct medicine or not at a prescribed time. The data will be updated into the web browser using the Wi-Fi module. After completely taking the medicines over days/months the device will be fixing an appointment with the doctor automatically by sending a message using the GSM module and also convey the same to the medical shops to deliver the required medicines to patients address or to the hospitals. Focuses on alerting the users, care-takers about the medicine intake time of the patients. When the pill box becomes empty it sends a purchasing notification to the medical shop about the medicines that has to be purchased. The device also fixes an appointment with the doctor when the usage of medicines is completed.

Viral Doshi et al (2019) made a device which consisted of a small box divided into 21 sections for storing pills for a week of up to 3 patients. The box was connected to an RTC module, an Arduino AT mega 2560. The RFID tag will be given to each patient. When it is brought close to the reader, the medication will be dispensed. RTC is used to compare the time the dosage is to be given with the current time. It will check whether the RFID tag is read by RFID reader. If the condition is true. The 5 box will open about 60 sec and then the section will be closed, also it will store data as DOSAGE TAKEN. It will then go back to monitor the current time. If the condition is false and 30 sec after the notification was sent are completed the LED and BUZZER will be turned off. It shall then check for the current time is equal to set time + 5 minutes, if the condition is true, the patient will receive the second reminder. The LED and BUZZER will be turned on again for 30 sec. If the RFID tag is not detected the data would be stored as dosage missed. WIFI-module is used in sending the results which will be stored in the database.

3. PROPOSED SYSTEM

The proposed medicine drug admin system is integrated of both hardware and software. This system used IOT android based RTC time, buzzer and ESP32 model microcontroller, regulated power supply section for sign conversion system using python programming. When the set time is match with controller data base time then automatically medicine box will open to consume medicine pill. A smart system that will continuously cover the case's health with the help of a detector and also at the same time will cover the patient diurnal cure of drug. Each drug box will have its own set of timing information which will be compared to a real worldclock. However, the buzzer will go out and thereby remind the case to take his/her drug, If the information matches. A data will also be maintained regarding the case's health and his diurnal input of drugs. Propose a smart system that will continuously cover the case's health with the help of a detector and also at the same time will cover the cases daily cure of drug Each drug box will have its

IOT-ENABLED AUTOMATED PILL REMINDER FOR STREAMLINED MEDICINE MANAGEMENT AND PATIENT ADHERENCE

own set of timing information which will be compared to a real world clock. However, the buzzer will go out and thereby remind the case to take his/ her drug A data will also be maintained regarding the case's health and his diurnal input of drugs, If the information matches.

The 16x2 LCD serves as the interface through which the user can select the compartment for which they want to set the time, they can select the time for 3 compartments titled med 1, med 2 and med 3. This is done by the help of the rotatory encoder which acts as the knob by turning the knob clockwise and anticlockwise we can scroll through the list of options provided. The time that has been selected by the user will then be displayed on the LCD for a min or two and then will move to the default screen which displays the current date and time The time that has been selected will be stored in the eeprom of the arduino and at that time set, the buzzer and the led which serves as the audio and visual indicator respectively is activated. There are 3 LED present to indicate the 3 compartments and only the LED corresponding to the compartment will glow so the patient can know that it's time and which compartment they have to reach out for their medication.

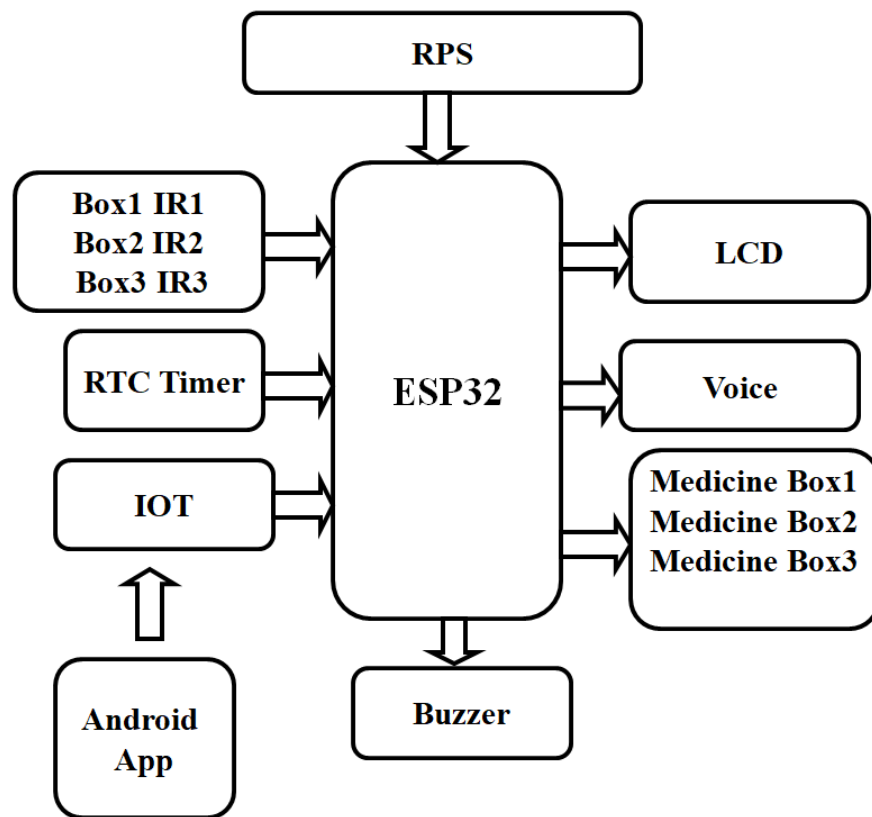

Fig.1. Architectural Block diagram of the Project.

The RPS module converts the 230 ac volts into 5v of dc. The 5v of power supply goes to all components in the system. The input of the project is RTC and IOT module. The RTC has CMOs battery and RTC circuit and it counts the time and opens the medicine box. The IOT server can send the data and display the data in the IOT server app. The output has LCD, Buzzer alarm and dc motor, In the Arduino microcontroller

contains the software programming code Embedded C. The main purpose of the microcontroller is the data can be control by the microcontroller.

Once we should ON the kit first Reset the kit because to connect wifi to IOT server. The kit is reset the LCD displays the Medicine Remainder. After we configure to IOT server by using an TCP Telnet Terminal app. By using our mobile phone we can connect the wifi to IOT server. Once the wifi is ON the mobile data should be OFF. By using the IP address 192.168.4.1 and port:23 connect the IOT server. Once it is connected the LCD displays the present Date and Time.

Next we can the set the time for reminding the Medicine we can use the command like @HH:MM:SS# . We can give the Eight commands first we can save and then send the LCD displays the configurations of reminders. The first two commands are getting the same voice and similarly the next six commands also. The next command is for the reminding purpose. Not only giving the voice we can also see the name of the medicine on the LCD and at the same time IOT app.

In real time once we can set the commands it working on 24/7 until the power is OFF. Suppose the power is OFF we can again set the commands.

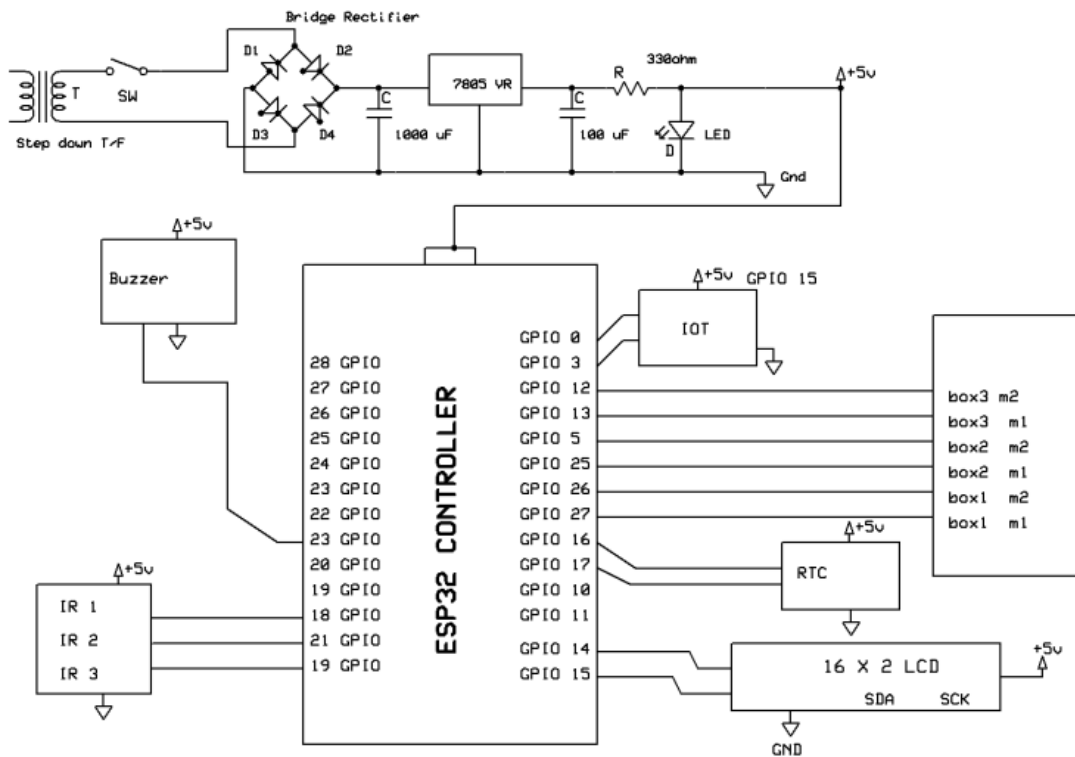

Arduino sketch that functions as a medicine drug admin system using an Arduino board, a Real-Time Clock (RTC) module, a Liquid Crystal Display (LCD) module. The system is designed to remind users to take

IOT-ENABLED AUTOMATED PILL REMINDER FOR STREAMLINED MEDICINE MANAGEMENT AND PATIENT ADHERENCE

their medication at specific times by displaying messages on the LCD and dc motor opens the medicine box. The proposed system designed to configure and manage medication reminder times, display the current date and time on an LCD, and trigger dc motor box to remind users to take their medication. It uses an RTC module to keep track of time and EEPROM memory to store configuration data. However, there are a few issues with the code, such as incorrect variable names and potential logic errors, which might need further debugging and refinement for the system to work correctly. not used in the provided code. It seems to have been intended to set up a WiFi connection.

The LED and the buzzer can be switched off with the help of a button and if that's not the case they automatically stop after a min Another button is present which controls the micro servo motor that serves the purpose of opening the box and for sending the SMS to the guardian based on the button input a SMS will be sent. For instance if the button is not pressed the box remains in the same place as such a conclusion can be drawn, that the patient has Fig 4.3.1.1 Proposed system 14 failed to take their medication at the specified time and so an SMS will be sent to indicate this. On the other hand if they press the button the servo pushes the box forward and so the patient has taken said medication and hence a corresponding SMS will be sent to convey this information to the guardian/caretaker.

ADVANTAGES: -

1) Cost efficient

Our product cost is affordable compare to other product available in market.

2) User friendly

User can set time table of medicine by himself.

3) Highly reliable

Good in quality and performance; able to be trusted for patients & old age people.

4) Easy to use and manufacture

It is very easy to use and manufacture.

5) Accurate result

Alarm will ring at proper time which is set by user previously. Easy to maintain: It need less Maintenance. It is one time investment afterwards it can be used continuously.

6) Enhanced Medication Adherence

Automated reminders and real-time monitoring improve patient compliance, ensuring medications are taken as prescribed.

7) Real-Time Monitoring

Continuous monitoring of patient adherence, allowing healthcare providers to intervene promptly if issues arise.

8) Improved Patient Outcomes

Enhanced adherence often leads to better health outcomes, reducing the risk of complications and hospital readmissions.

9) Cost Savings:

Preventing medication-related complications and hospital readmissions can result in cost savings for healthcare systems.

10) Reduced Human Error:

Automation minimizes the risk of errors associated with manual medication administration, improving patient safety.

11) Emergency Alerts

Prompt notification of missed doses or emergencies allows for immediate intervention, reducing potential health risks.

12) Improved Patient Experience

Simplifying medication management with user-friendly interfaces and reducing the burden on patients and caregivers.

APPLICATIONS:

1) Medication Adherence Monitoring

Ensuring patients take medications on time through automated reminders and tracking.

2) Remote Patient Monitoring

Enabling healthcare providers to remotely monitor patient drug adherence and adjust treatment plans as needed.

3) Inventory Management

Tracking medication levels in real-time, automating reorders, and preventing stockouts.

4) Temperature and Storage Monitoring

Using IoT sensors to monitor environmental conditions to ensure proper storage of medications.

5) Data Analytics for Healthcare Providers

Analyzing patient adherence patterns to improve treatment outcomes and personalize care.

6) Emergency Alerts

Providing real-time alerts to healthcare providers or caregivers in case of missed doses or emergencies.

7) Integration with Electronic Health Records (EHR)

Seamlessly integrating with existing healthcare systems for a comprehensive patient profile.

8) User-Friendly Interfaces

Developing intuitive mobile apps for patients to easily view and manage their medication schedules.

9) Cost Reduction

Optimizing medication management can lead to cost savings by reducing hospital readmissions and improving overall health outcomes.

4. RESULTS

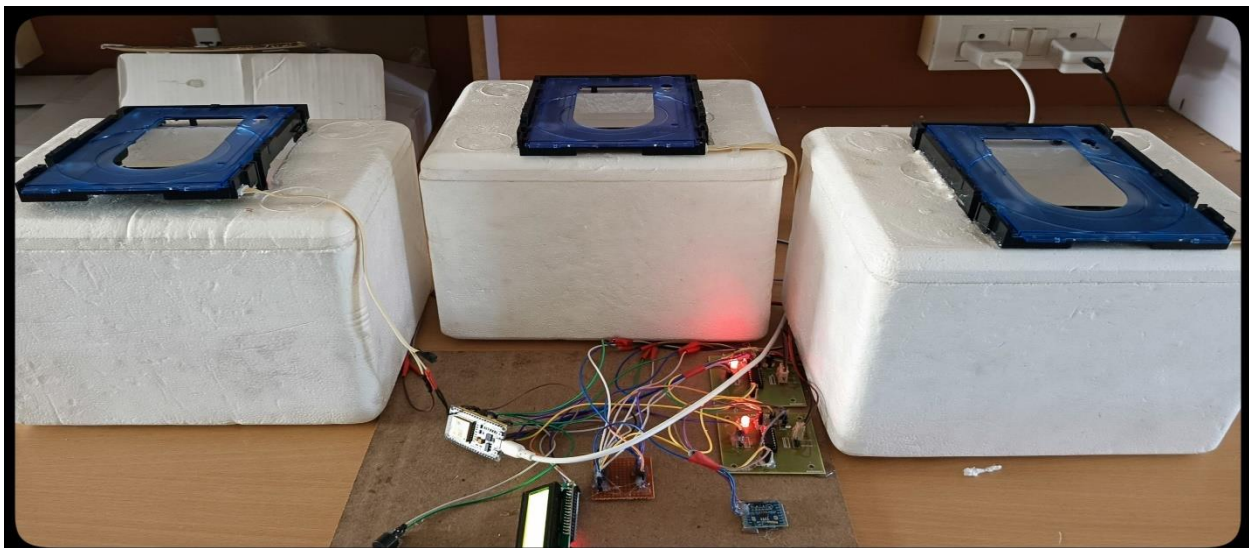

IOT-ENABLED AUTOMATED PILL REMINDER FOR STREAMLINED MEDICINE MANAGEMENT AND PATIENT ADHERENCE

The above image shows the hardware equipment of the project. The kit is turned ON by giving the regulated power supply of 12v which is then converted to 5v dc current. The generated 5v dc current passes to every hardware component in the circuit.



The above figure indicates the LCD display. After connecting the regulated power supply, the ESP 32 has a wi-fi module by connecting the hotspot to it, the title (SMART DIGITAL DRUG ADMIN) is display on the LCD screen.

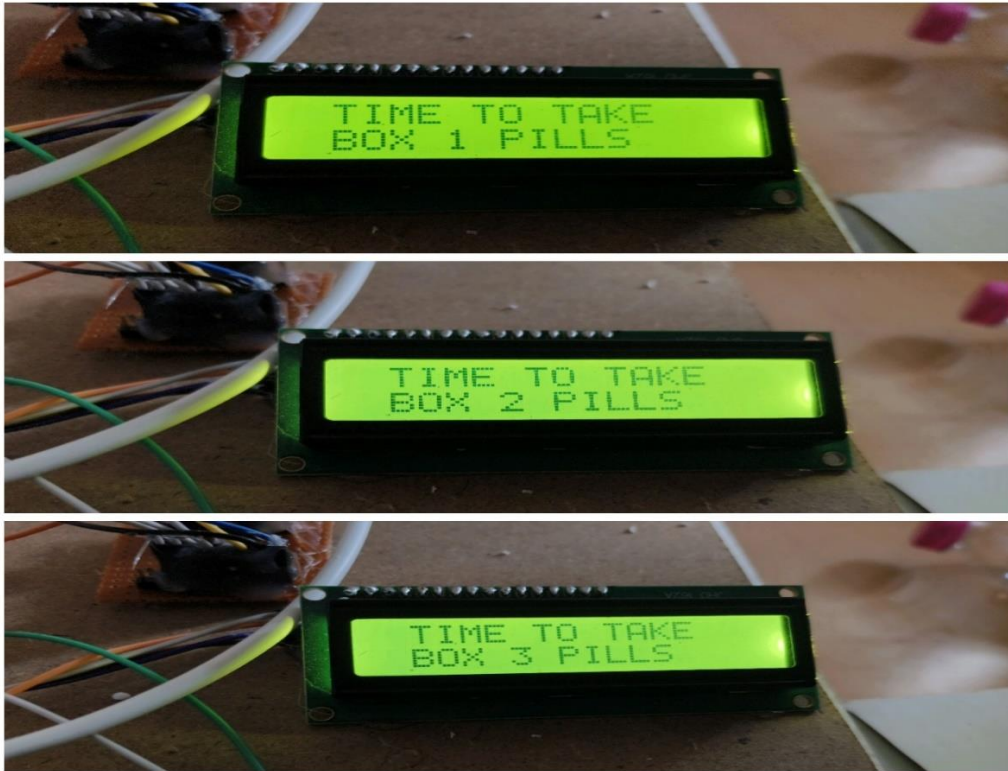

The above figure indicates the reminder to take the medicine. For taking the medicine the time slot has fixed in the android app. The corresponding message was displayed on the LCD screen for respective box. For example the time slot has fixed for the morning, afternoon and evening session.

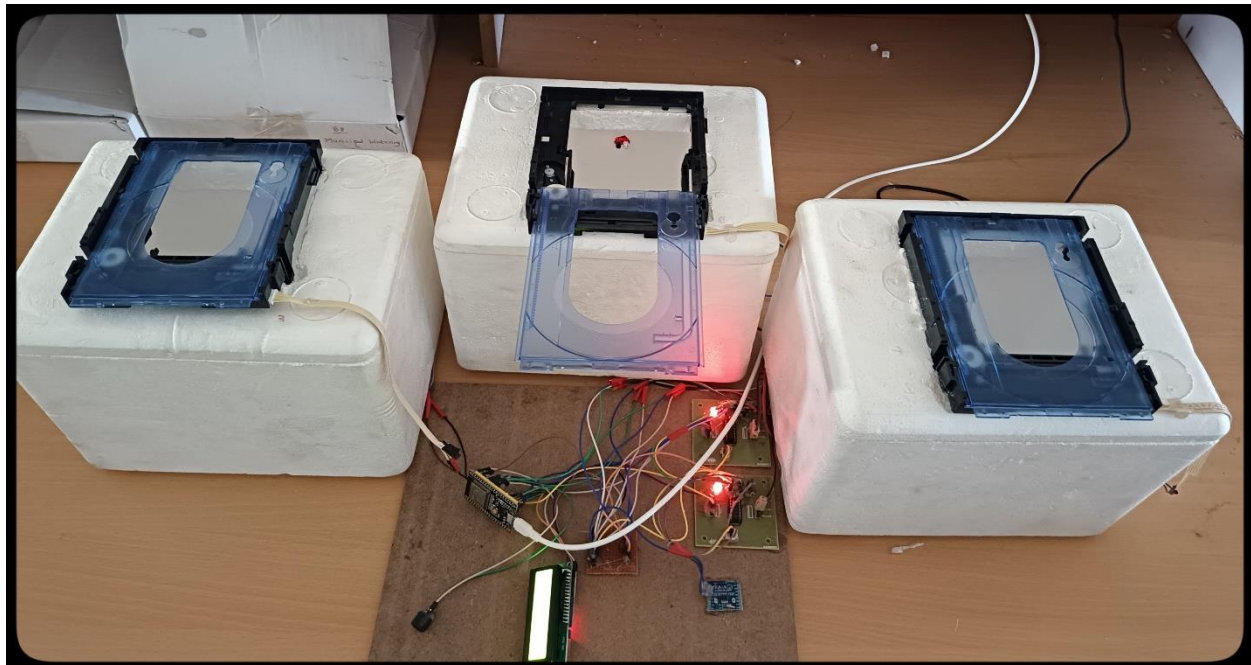

IOT-ENABLED AUTOMATED PILL REMINDER FOR STREAMLINED MEDICINE MANAGEMENT AND PATIENT ADHERENCE

The above figure indicates the opening of the medicine box, when the message is displayed on the LCD screen the respective box was opened for one minute and it will close automatically after one minute.

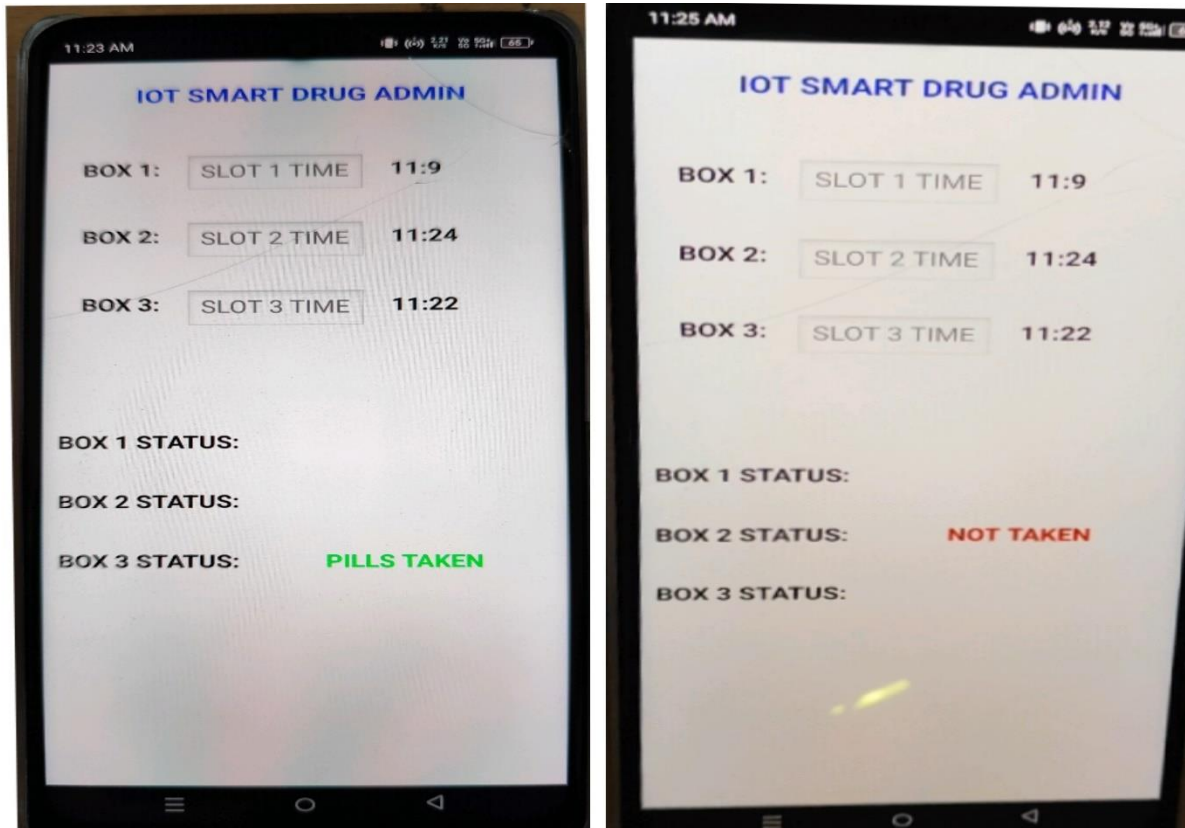

The above figure indicates the interface of the IOT server android app. When the medicine box opened for one minute if patient take the medicine the android app displays the “PILLS TAKEN” message in the box status and it will send corresponding voice over, vice versa if patient does not take the medicine the android app displays the “NOT TAKEN” message in the box status and it will send the corresponding voice over.

5. CONCLUSION

Overview of the project is “IOT RTC based smart drug admin gives the medicine box automatically open and close for easy consumption of medicine at correct time.” the main aim of the project reminding the medicine for the people who are having the health problems Mentally elderly and Physically. In this project we are using the RTC timer and IOT module transmitting the data. And the data can be controlled by Microcontroller. By using the wifi connect the IOT server. The data can display on the LCD display and at the same time IOT server. The medicine box will be open through the dc motor module.

REFERENCES

- [1] Savithaa. N, Savitha.P, Trisha.S, Subhashree.C, 'Intelligent medicine box for medication management using IOT' International Research Journal of Engineering and Technology (IRJET) e-ISSN: 2395-0056 Volume: 08 Issue: 12 | page no 1390- 1392, Dec 2021
- [2] Karthikeyan, K. R., Babu, E. D., Ranjith, S., &Arunkumar, S. (2021, October). Smart Pill Dispenser for Aged Patients. In 2021 International Conference on Advancements in Electrical, Electronics, Communication, Computing and Automation (ICAECA) (pp. 1-5). IEEE
- [3] Divya Sai.K, SwarnaLatha.S ,Shoban Babu'.B "IoT Based Smart Pill Box Using Arduino Microcontroller", International Journal of Emerging Technologies and Innovative Research (www.jetir.org), ISSN:2349-5162, Vol.8, Issue 1, page no.370-375, January-2021,
- [4] Anandhapadmanaban .S, Ashifa .A, Sanjay Kumar .S, Suryalakshmi .R, ' A Smart Medicine Box for Medication Management using IoT' Journal of Xi'an University of Architecture & Technology, Volume XII, Issue V, page no.1169- 1173, 2020
- [5] Rao, A., Pranathi, B. S., Shivani, A., & Mohan, R. (2020, July). IoT based Smart Medicine Kit. In 2020 IEEE International Conference on Electronics, Computing and Communication Technologies (CONECCT) (pp. 1-6). IEEE.
- [6] Nur Zulaikhah Nadzri1, Yusman Yusof, Ahmad Firdaus Ahmad Fazil, 'Ibox: Smart Medicine Box With Iot Application' European Journal of Molecular & Clinical Medicine ISSN 2515-8260 Volume 07, Issue 08, pp. 3747-3757 2020
- [7] Latif, G., Shankar, A., Alghazo, J.M. et al. ICARES: advancing health diagnosis and medication through IoT. *Wireless Netw* 26, 2375–2389 (2020)
- [8] Harshitha V, Sandeep K, Swasthika Jain T J, 'An Interactive Pill Box using IoT', International Journal of Engineering and Advanced Technology (IJEAT)ISSN: 2249-8958 (Online), Volume-9 Issue-3, page- no 2436-2438 ,February 2020
- [9] Viral Doshi, Shrishti Dey, Nirav Mehta, Rajesh Prasad, 'An IoT based smart medicine box', International Journal of Advance Research, Ideas and Innovations in Technology, Volume 5, Issue 1, page no 205-207, 2019